

LNA Design

Peter Wright

The Law of Signal to noise Ratio

- With your First Gain Stage you set the relationship of Wanted Signal to System Noise for everything that comes after.
- This first Gain stage should give you as much Gain as Possible.

The Signal in General

- Is the Signal Bandwidth that gets Amplified to the Pass band 3dB Points (Half Power)
- The Amplifier amplifies every thing that it sees !

IF!

- IF An amplifier sees a very strong signal on an adjacent channel say 10MHz away it will go into saturation and your weak Radio Astronomical signal will be lost . The only solution here is to reduce what the amplifier sees to Radio Astronomy Sources.

How do you do this

- Design the feed to see nothing else (pass band of the feed horn) Antenna design in general (Trough , Corner Reflector) pointing to the Sky Binkers, Side wall .
- Or use a Filter
- Or kill the intruder with a notch filter (Resonant Stub)

If You win something you loose something else !

- Yes If a filter is placed in front of your gain stage it obviously has an attenuation of your wanted signal .
- Here you can help by keeping this loss Low Helical Filter (Neosid) Interdigital filter Filter Silver Plated .
- The angle of your filter needs to be steep !

Filter Curve

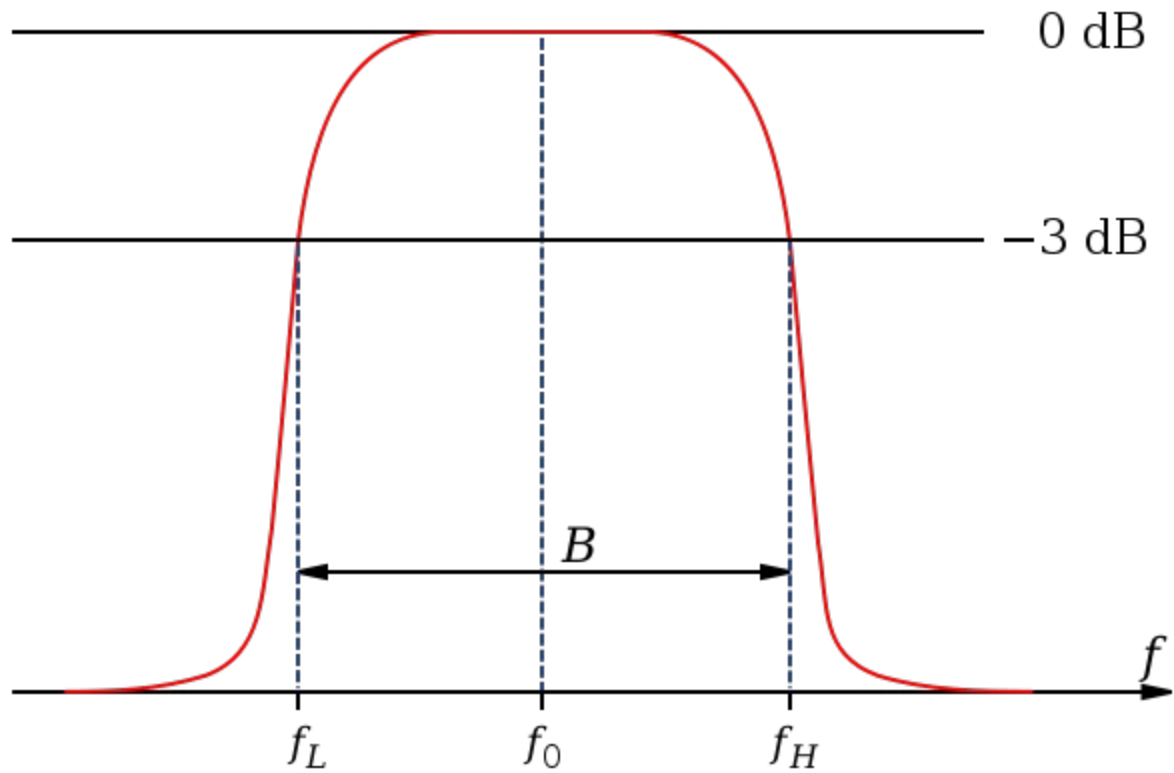

Forward Bias

- If a Semiconductor Junction is open it will allow very weak signals to flow that otherwise would not pass !

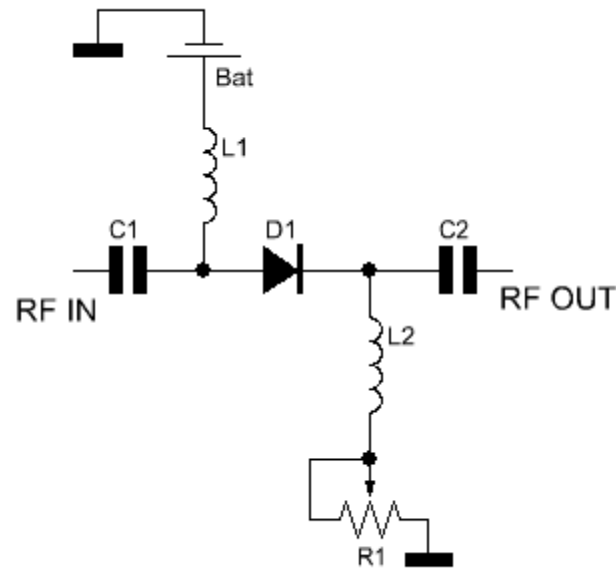

Negative Forward bias

The power Supply

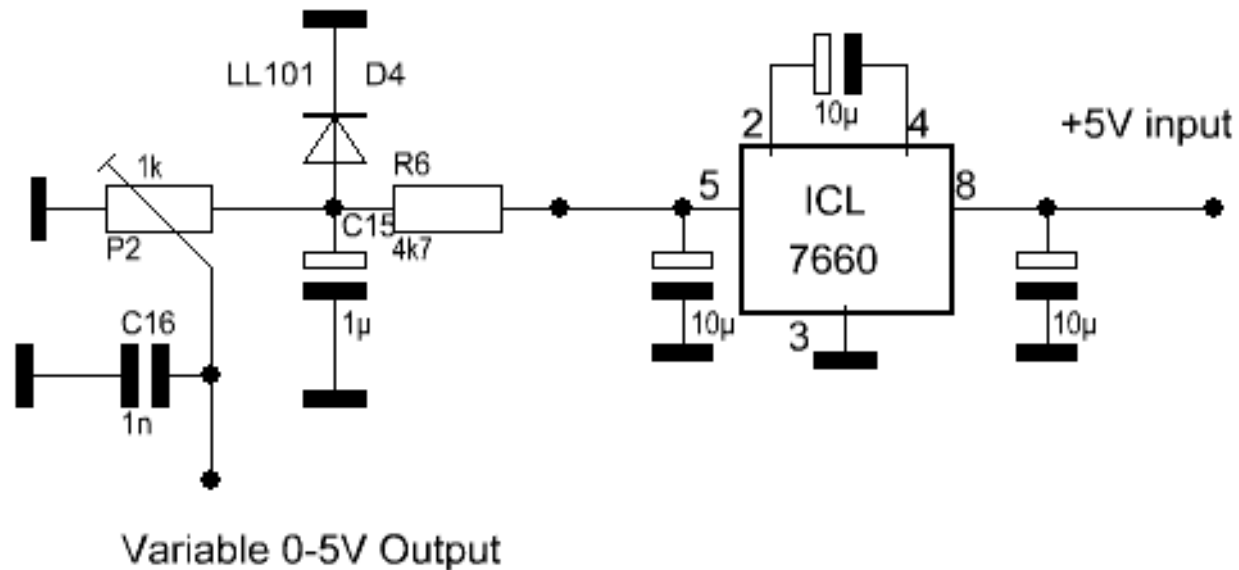

Selective L Band HEMT Pre Amp MKU172A

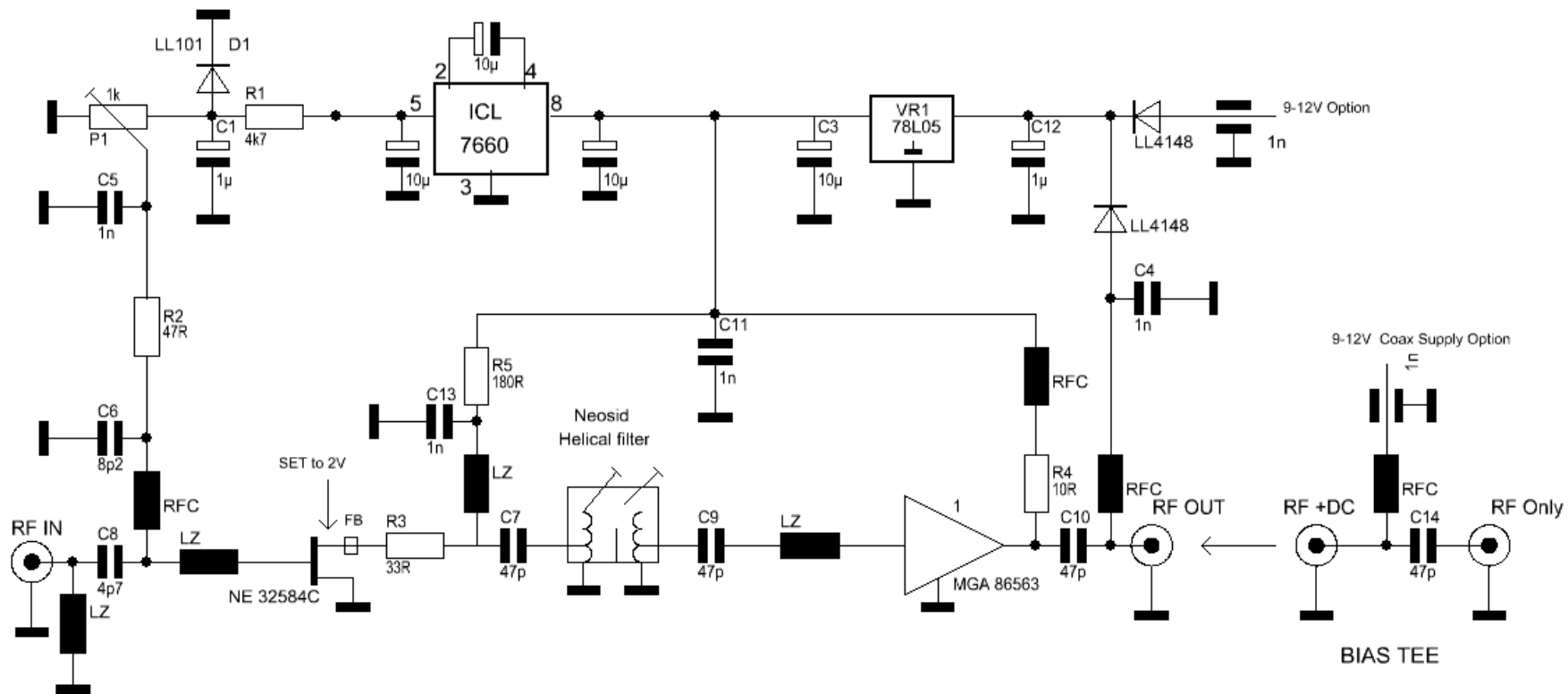

WWW.DB6NT.de

S/N 0.5dB Gain 44dB

NEC

DATA SHEET

HETERO JUNCTION FIELD EFFECT TRANSISTOR NE32584C

C to Ku BAND SUPER LOW NOISE AMPLIFIER
N-CHANNEL HJ-FET

DESCRIPTION

The NE32584C is a Hetero Junction FET that utilizes the hetero junction to create high mobility electrons. Its excellent low noise and high associated gain make it suitable for DBS, TVRO and another commercial systems.

FEATURES

- Super Low Noise Figure & High Associated Gain
NF = 0.45 dB TYP., G_{fs} = 12.5 dB TYP. at $f = 12$ GHz
- Gate Length : $L_g \leq 0.2 \mu\text{m}$
- Gate Width : $W_g = 200 \mu\text{m}$

ORDERING INFORMATION

PART NUMBER	SUPPLYING FORM	LEAD LENGTH	MARKING
NE32584C-SL	STICK	L = 1.7 mm MIN.	D
NE32584C-T1	Tape & reel 1000 pcs./reel	L = 1.0 ± 0.2 mm	
NE32584C-T1A	Tape & reel 5000 pcs./reel	L = 1.0 ± 0.2 mm	

ABSOLUTE MAXIMUM RATINGS (T_A = 25 °C)

Drain to Source Voltage	V _{DS}	4.0	V
Gate to Source Voltage	V _{GS}	-3.0	V
Drain Current	I _D	I _{DSS}	mA
Gate Current	I _G	100	μA
Total Power Dissipation	P _{tot}	165	mW
Channel Temperature	T _{ch}	150	°C
Storage Temperature	T _{stg}	-65 to +150	°C

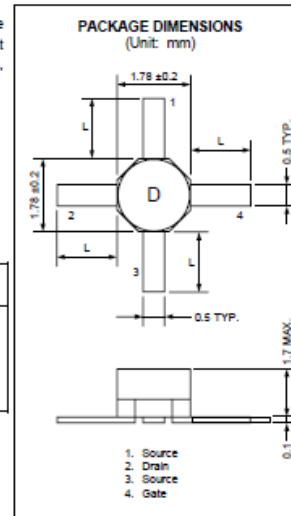

Pre Amp !

CHARACTERISTIC	SYMBOL	MIN.	TYP.	MAX.	UNIT	TEST CONDITIONS
Gate to Source Leak Current	I _{GS0}		0.5	10	μA	V _{DS} = -3 V
Saturated Drain Current	I _{DSS}	20	60	90	mA	V _{GS} = 2 V, V _{DS} = 0 V
Gate to Source Cutoff Voltage	V _{GS(off)}	-0.2	-0.7	-2.0	V	V _{DS} = 2 V, I _D = 100 μA
Transconductance	g _m	45	60		mS	V _{GS} = 2 V, I _D = 10 mA
Noise Figure	NF		0.45	0.55	dB	V _{GS} = 2 V, I _D = 10 mA, f = 12 GHz
Associated Gain	G _{fs}	11.0	12.5		dB	

0.5 – 6 GHz Low Noise GaAs MMIC Amplifier

Technical Data

Buffer!

Features

- Lead-free Option Available
- Ultra-Miniature Package
- Internally Biased, Single +5 V Supply (14 mA)
- 1.6 dB Noise Figure at 2.4 GHz
- 21.8 dB Gain at 2.4 GHz
- +3.1 dBm P_{1dB} at 2.4 GHz

Applications

- LNA or Gain Stage for ISM, PCS, MMDS, GPS, TVRO, and Other C band Applications



Attention: Observe precautions for handling electrostatic sensitive devices.

ESD Machine Model (Class A)

ESD Human Body Model (Class 0)

Refer to Agilent Application Note A004R: Electrostatic Discharge Damage and Control.

Equivalent Circuit

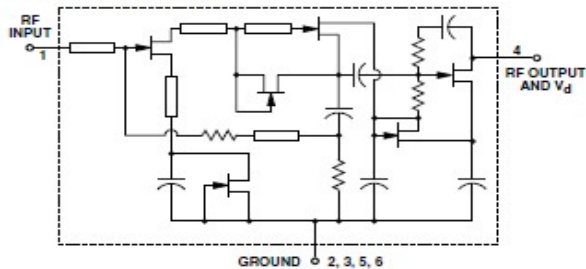

Surface Mount Package SOT-363 (SC-70)

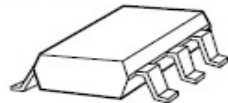

Pin Connections and Package Marking



Note: Package marking provides orientation and identification.

MGA-86563

Description

Agilent's MGA-86563 is an economical, easy-to-use GaAs MMIC amplifier that offers low noise figure and excellent gain for applications from 0.5 to 6 GHz. Packaged in an ultra-miniature SOT-363 package, it requires half the board space of the SOT-143.

The MGA-86563 may be used without impedance matching at a high performance 2 dB NF gain block. Alternatively, with the addition of a simple shunt-series inductor at the input, the device noise figure can be reduced to 1.6 dB at 2.4 GHz. For 1.5 GHz applications and above, the output is well matched to 50 Ω. Below 1.5 GHz, gain can be increased by using conjugate matching.

The circuit uses state-of-the-art PHEMT technology with self-biasing current sources, a source-follower interstage, resistive feedback, and on-chip impedance matching networks. A patented, on-chip active bias circuit allows operation from a single +5 V power supply. Current consumption is only 14 mA, making this part suitable for battery powered applications.

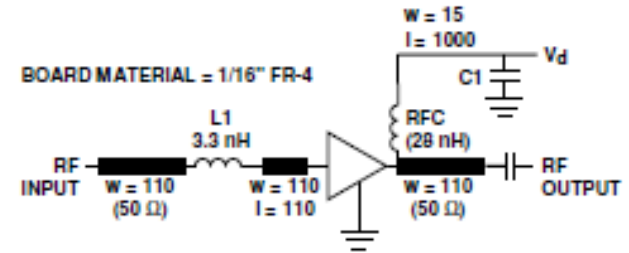

Figure 10. Test Circuit for 2 GHz.

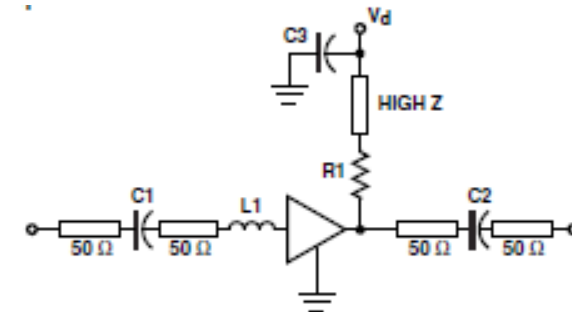

Figure 14. Typical Amplifier Circuit.

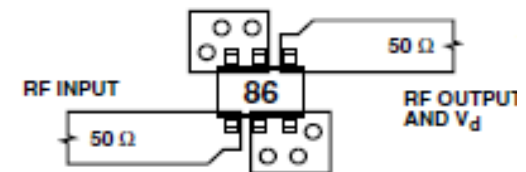
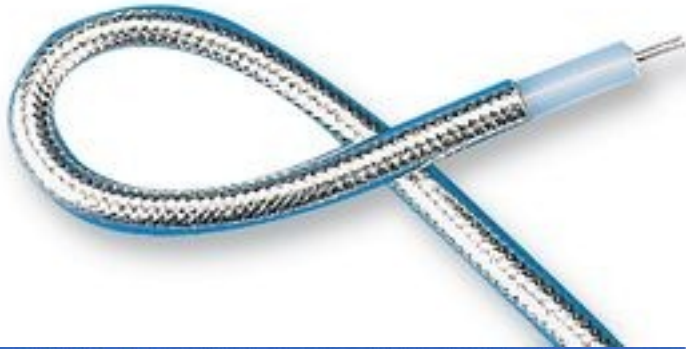

Figure 13. RF Layout.



RF Screening



37x74x30

Weißblechgehäuse

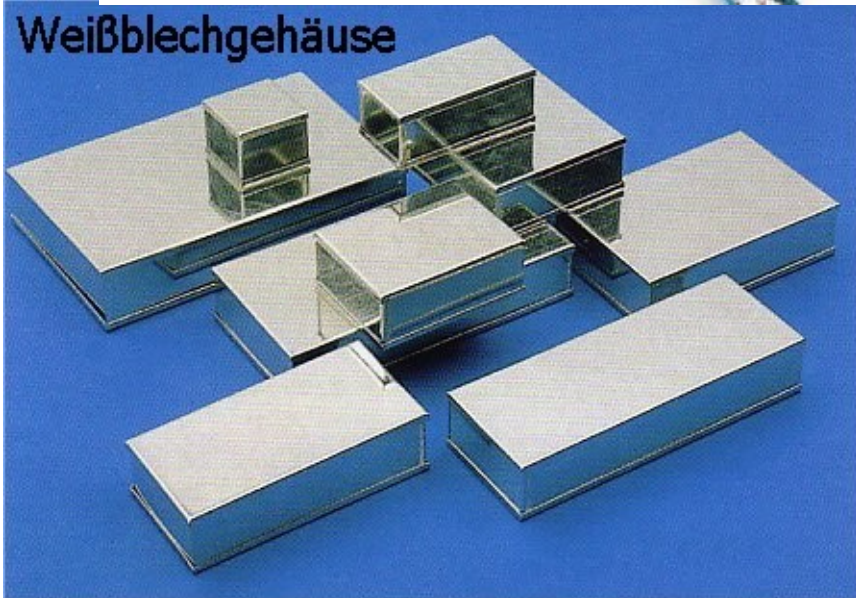

www.rfsup
www.rfsupplier.com
www.rfsupplier.com
www.rfsupplier.com
www.rfsupplier.com



<http://www.schubert-gehaeuse.de>

Power Supply Via Coax

- The advantage of using the coax for power is less cable and connectors .
- You do not inject unwanted signal into you gain stage
- UT141 Semi Rigid Coax and SMA Connectors

As of Yesterday the New
Technology !

PHEMT MMIC

From

Minicircuits

Low Noise, High IP3 Monolithic Amplifier

0.1-6 GHz

Product Features

- Single Positive Supply Voltage, 3V
- Low Noise Figure, 0.8 dB typ. at 1GHz
- High IP3, 36 dBm typ. 1GHz
- Gain, 20dB typ. at 1 GHz
- Output Power, up to +20dBm typ.
- Micro-miniature size
- Aqueous washable

Typical Applications

- Cellular
- ISM
- GSM
- WCDMA
- LTE
- WiMAX
- WLAN
- UNII and HIPERLAN



PMA-545+

CASE STYLE: DQ849
PRICE: \$1.49 ea. QTY. (10-49)

+ RoHS compliant in accordance with EU Directive (2002/95/EC)

The +Suffix has been added in order to identify RoHS Compliance. See our web site for RoHS Compliance methodologies and qualifications.

General Description

PMA-545+ is a high dynamic range, low noise, high IP3, high output power, monolithic amplifier. Manufactured using E-PHEMT* technology enables it to work with a single positive supply voltage. Unconditionally stable over the operating frequency.

simplified schematic and pad description

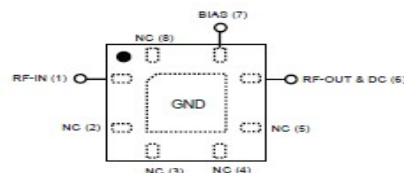
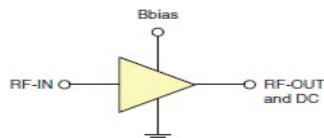

Function	Pad Number	Description**
RF-IN	1	RF input pad
RF-OUT & DC	6	RF output pad (connected to RF-OUT via blocking external cap C2, and Supply voltage Vs via RF Choke L1 (see application circuit))
BIAS	7	Bias pad (connected to Vs via Rbias)
GND	paddle in center of bottom	Connections to ground
NOT USED	2,3,4,5,8	No internal connection; recommended use: per PCB Layout PL-299

* Enhancement mode Pseudomorphic High Electron Mobility Transistor.
** Refer to Application Circuit Fig. 2

Mini-Circuits®
ISO 9001 ISO 14001 AS 9100 CERTIFIED

P.O. Box 350166, Brooklyn, New York 11235-0003 (718) 934-4500 Fax (718) 332-4661 For detailed performance specs & shopping online see Mini-Circuits web site
The Design Engineers Search Engine Provides ACTUAL Data Instantly From MINI-CIRCUITS At: www.minicircuits.com

IF/RF MICROWAVE COMPONENTS

minicircuits.com

REV. OR
M121874
PMA-545+
ED-13485
THRS/CP/AM
000626
Page 1 of 5

Electrical Specifications⁽¹⁾ at 25°C, Zo=50Ω, Rbias=432Ω (refer to application circuit)

Parameter	Condition (GHz)	Min.	Typ.	Max.	Units
Frequency Range		0.1		6.0	GHz
DC Voltage (V _d)			3.0		V
DC Current (I _d)		65	80	98	mA
DC Current (I _{Rbias})			5.6		mA
Noise Figure	0.1	→	0.8	1.3	dB
	0.5		0.8		
	1.0		0.8		
	2.0		1.0		
	3.0		1.2		
	4.0		1.5		
	5.0		2.0		
Gain	0.1	12.7	26.0	15.6	dB
	0.5		23.3		
	1.0		19.4		
	2.0		14.2		
	3.0		11.1		
	4.0		8.9		
	5.0		7.0		
Input Return Loss	0.1-0.5		11.0		dB
	0.5-6		7.0		
Output Return Loss	0.1-4		20.0		dB
	4-6		16.0		
Output IP3	0.1	→	33.4		dBm
	0.5		35.1		
	1.0		36.3		
	2.0		36.4		
	3.0		38.1		
	4.0		40.0		
	5.0		36.0		
Output Power @ 1 dB compression ⁽²⁾	0.1	18.3	19.8		dBm
	0.5		19.9		
	1.0		19.3		
	2.0		20.3		
	3.0		20.1		
	4.0		20.7		
	5.0		20.0		
DC Current Variation vs. Temperature ⁽³⁾			-0.121		mA/°C
			128		°C/W

Recommended Application Circuit

(refer to evaluation board for PCB Layout and component values)

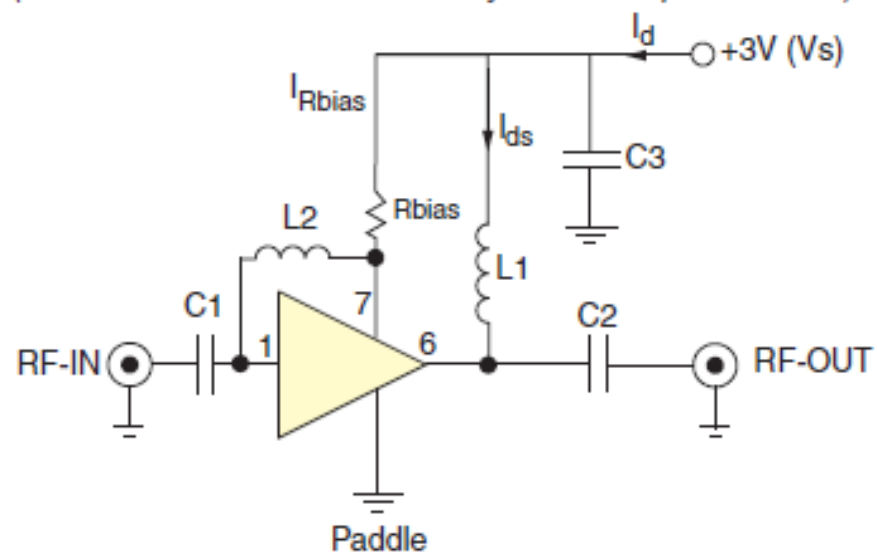

Monolithic Amplifier

0.05-6 GHz

Product Features

- High IP3, 42 dBm typ. at 2 GHz
- Gain, 13.5 dB typ. at 2 GHz
- High Pout, P1dB 22 dBm typ. at 2 GHz
- Low noise figure, 2.7dB @2 GHz
- No external matching components required
- May be used as replacement for WJ AH1^{a,b}



PHA-1+

CASE STYLE: DF782
PRICE: \$1.49 ea. QTY. (50)

+ RoHS compliant in accordance with EU Directive (2002/95/EC)

The +Suffix has been added in order to identify RoHS Compliance. See our web site for RoHS Compliance methodologies and qualifications.

Typical Applications

- Base station infrastructure
- Portable Wireless
- CATV & DBS
- MMDS & Wireless LAN
- LTE

General Description

PHA-1+ (RoHS compliant) is an advanced wideband amplifier fabricated using E-PHEMT technology and offers extremely high dynamic range over a broad frequency range and with low noise figure. In addition, the PHA-1+ has good input and output return loss over a broad frequency range without the need for external matching components. Lead finish is SnAgNi. It has repeatable performance from lot to lot and is enclosed in a SOT-89 package for very good thermal performance.

simplified schematic and pin description

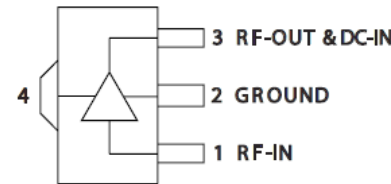
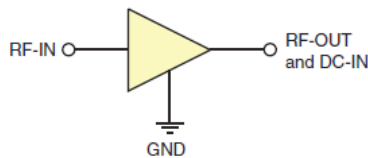

Function	Pin Number	Description
RF IN	1	RF input pin. This pin requires the use of an external DC blocking capacitor chosen for the frequency of operation.
RF-OUT and DC-IN	3	RF output and bias pin. DC voltage is present on this pin; therefore a DC blocking capacitor is necessary for proper operation. An RF choke is needed to feed DC bias without loss of RF signal due to the bias connection, as shown in "Recommended Application Circuit", Fig. 2
GND	2,4	Connections to ground. Use via holes as shown in "Suggested Layout for PCB Design" to reduce ground path inductance for best performance.

Notes:

a. Suitability for model replacement within a particular system must be determined by and is solely the responsibility of the customer based on, among other things, electrical performance criteria, stimulus conditions, application, compatibility with other components and environmental conditions and stresses.

b. The WJ AH1 part number is used for identification and comparison purposes only.

Electrical Specifications⁽¹⁾ at 25°C and 5V, unless noted

Parameter	Condition (GHz)	Min.	Typ.	Max.	Units
Frequency Range		0.05		6	GHz
Gain	0.05	15.4	17.2	18.9	dB
	0.8	14.1	15.7	17.3	
	2.0		13.5		
	3.0		11.8		
	4.0	9.6	10.7	11.8	
	6.0		9.7		
Input Return Loss	0.05		16.4		dB
	0.8	13.0	17.0		
	2.0		11.3		
	3.0		10.2		
	4.0		10.2		
	6.0		8.6		
Output Return Loss	0.05		18.8		dB
	0.8	13.0	17.1		
	2.0		12.1		
	3.0		11.3		
	4.0		11.2		
	6.0		9.4		
Reverse Isolation	2.0		19.9		dB
Output Power @ 1 dB compression	0.05	20.0	22.2		dBm
	0.8	20.0	22.6		
	2.0	20.0	22.4		
	3.0		22.7		
	4.0		22.7		
	6.0		21.6		
Output IP3	0.05		34.0		dBm
	0.8	37.0	41.1		
	2.0		42.0		
	3.0		42.3		
	4.0		43.3		
	6.0		41.0		
Noise Figure	0.05		3.0		dB
	1.0		2.4		
	2.0		2.7		
	3.0		2.8		
	4.0		3.0		
	6.0		3.7		
Device Operating Voltage		4.8	5.0	5.2	V
Device Operating Current		120	157	180	mA
Device Current Variation vs. Temperature			-315		μA/°C
Device Current Variation vs Voltage			0.054		mA/mV
Thermal Resistance, junction-to-ground lead			71		°C/W

⁽¹⁾ Measured on Mini-Circuits Characterization test board TB-313. See Characterization Test Circuit (Fig. 1)

Recommended Application Circuit

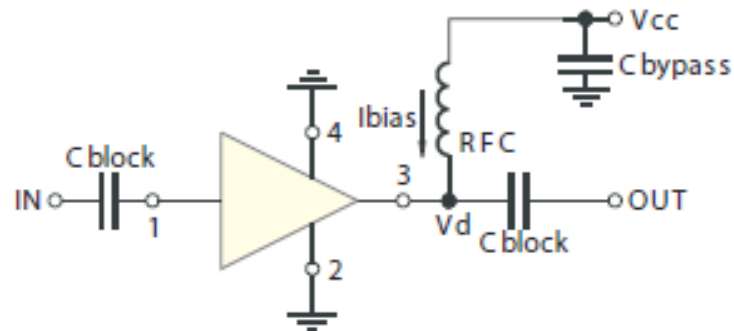

Fig 2. Test Board includes case, connectors, and components soldered to PCB

Both chips are optimized to be used together in a 2 stage pre amp