

Cooling a front end

ERAC Congress 2009

University of Applied Science

Heidelberg

Peter Wright

ERAC President

The Thermal blocks Job

- A Cascade cooling block providing Super Cold Via “Cold fingers” directly to Semiconductors in Gain stages (Conduction)
- General cooling to the rest of the Electronics in the housing (AIR Convection)
- Slow cooling down to avoid mechanical stress to the LNA

Air cooling to Temperature of the primery cooling
Silicone oil of the Lauda Cryostate

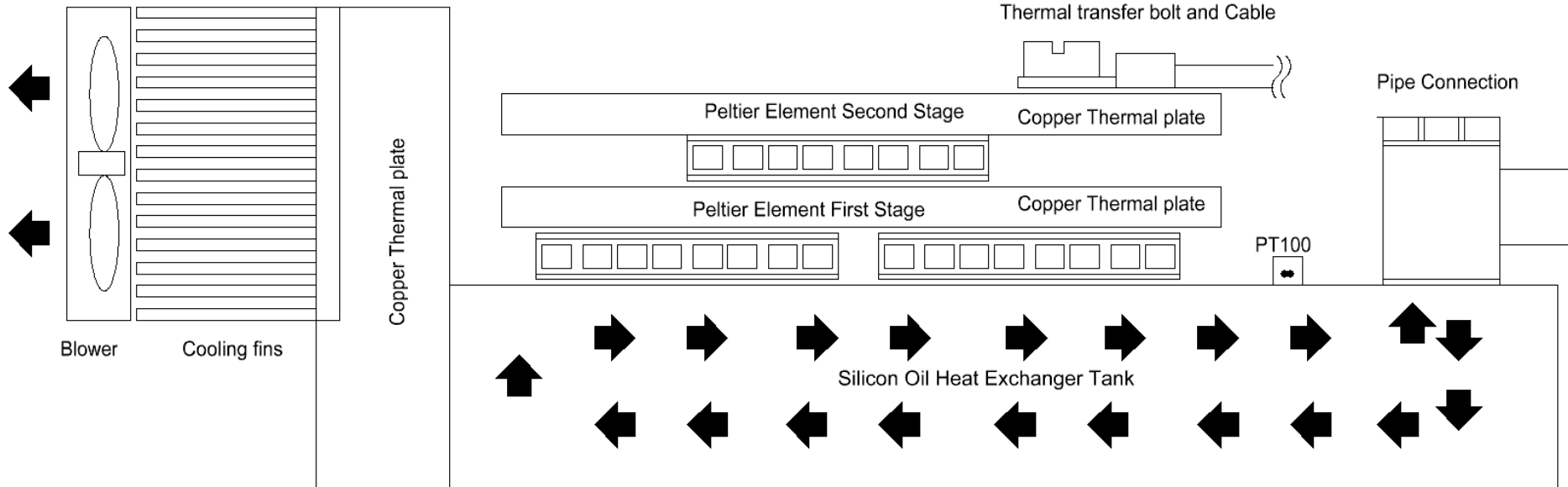

Thermal Cooling Block In the New Design front end 21cm

Thermal Transfer Bolt and Cable

- From the cooling block cold needs to get to the Cold finger on the LNA this works wonderfully with thick copper cable fitted with e crimp Eyes Soldered to the ends then wrapped up in an Armourflex Tape Multi-layer blanket to “make a sausage role”
- The LNA End is fitted also with a PT100 Sensor with all 4 leads inside the Armorflex Tape

The LNA Cold Finger

- Is a small 15mm Cylinder Turned on a lathe made out of brass with on one end an M6 Thread.
- The other end needs to be Tinned then soldered behind the First Gain element on the Rear Substrate Ground plain.
- Use Armorflex tape in this area to insulate well .
- This allows Easy connection of the cold cable with PT100!

Important parts used

- 12mm Standard Industrial Pneumatic pipe.
- Only Screw thread pipe fittings not Quick fit
- Armourflex Pipe insulation +GLUE
- Insulate long runs in in the Focus with Rescue Blanket Material “Silver side outside”
- 4mm Armourflex Tape with adhesive.





Important Considerations

- If the Peltier stage is turned on without coolant Circulating everything gets incinerated.
- The Size of the cooling unit in the Front end needs to be small.
- Temperature Cycling kills Electronics
- Condensed Water !

Front End Cooling Concept

Front End

Back End

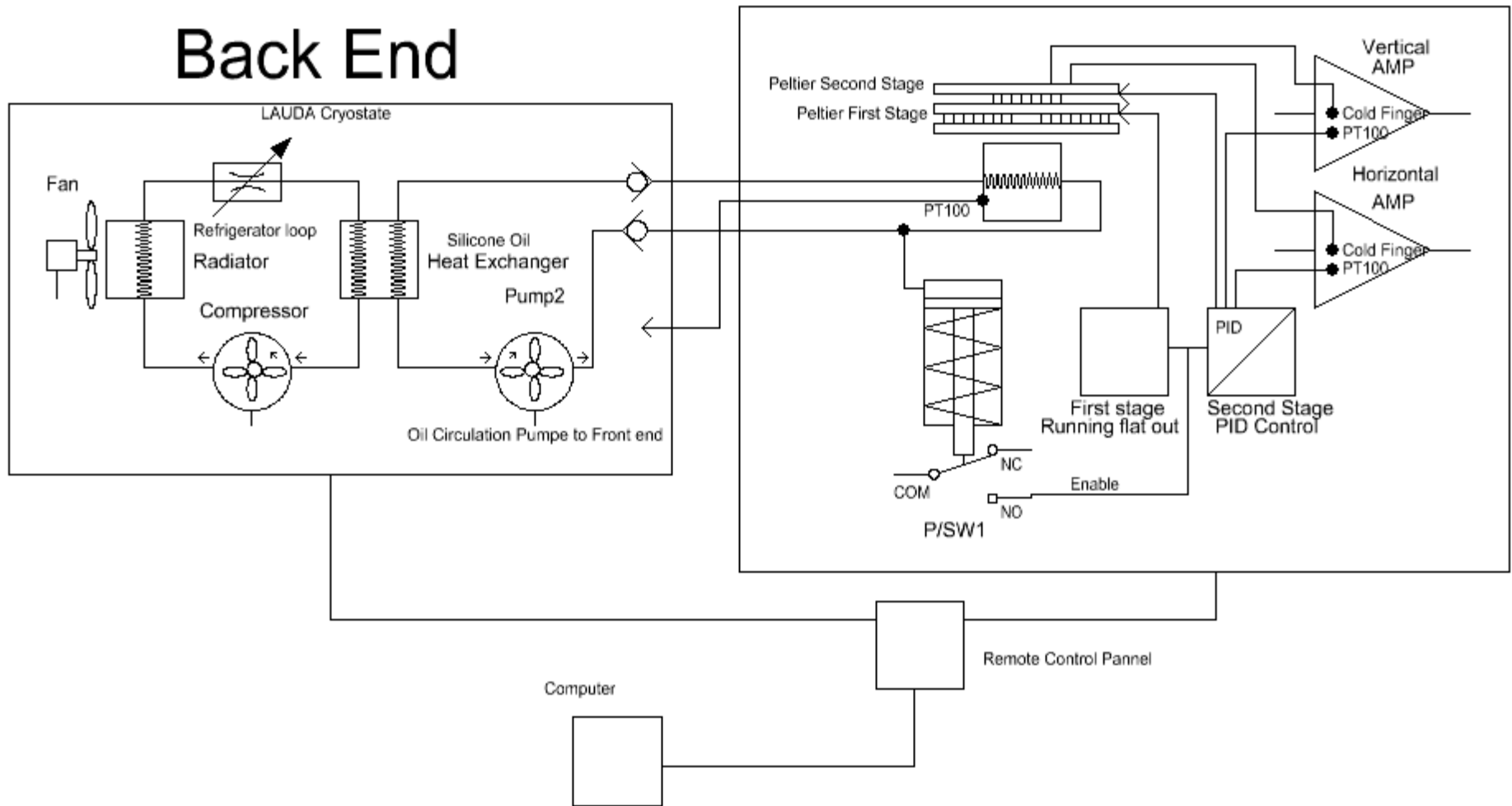

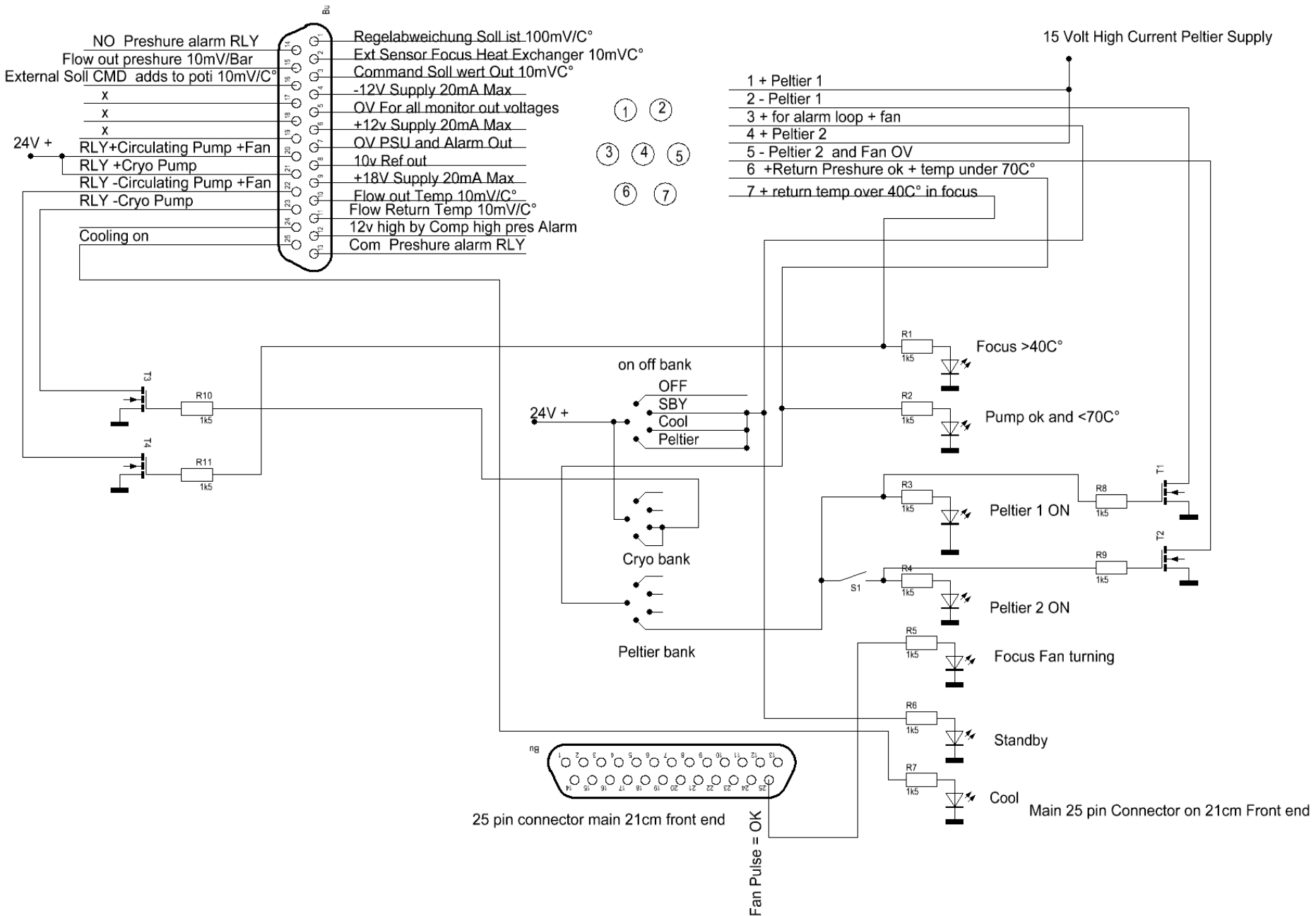

- | | |
|--|---|
| NO Preshure alarm RLY | Regelabweichung Soll ist 100mV/C° |
| Flow out preshure 10mV/Bar | Ext Sensor Focus Heat Exchanger 10mV/C° |
| External Soll CMD adds to poti 10mV/C° | Command Soll wert Out 10mV/C° |
| x | -12V Supply 20mA Max |
| x | OV For all monitor out voltages |
| x | +12v Supply 20mA Max |
| RLY+Circulating Pump +Fan | OV PSU and Alarm Out |
| RLY +Cryo Pump | 10v Ref out |
| RLY -Circulating Pump +Fan | +18V Supply 20mA Max |
| RLY -Cryo Pump | Flow out Temp 10mV/C° |
| Cooling on | Flow Return Temp 10mV/C° |
| | 12v high by Comp high pres Alarm |
| | Com Preshure alarm RLY |

- 1 + Peltier 1
- 2 - Peltier 1
- 3 + for alarm loop + fan
- 4 + Peltier 2
- 5 - Peltier 2 and Fan OV
- 6 +Return Preshure ok + temp under 70C°
- 7 + return temp over 40C° in focus

15 Volt High Current Peltier Supply

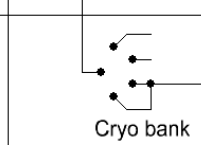
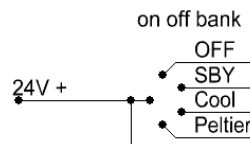

Peltier bank

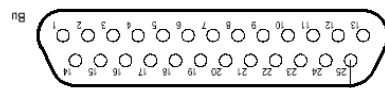

25 pin connector main 21cm front end

Fan Pulse = OK

R1 1k5

Focus >40C°

R2 1k5

Pump ok and <70C°

R3 1k5

Peltier 1 ON

R4 1k5

Peltier 2 ON

R5 1k5

Focus Fan turning

R6 1k5

Standby

R7 1k5

Cool

R8 1k5

R9 1k5

T1

T2

Main 25 pin Connector on 21cm Front end

Thermal Plan

- The Silicon oil Cooling Unit runs down to -60° from T Ambient
- T Ambient is -10°C in winter and up to $+50^{\circ}\text{C}$ in Somer..
- The first Peltier stage cools down -60°
- The Second at its best cools down another -40°C
- “ -100°C is possible in Winter”
- “ -10°C in Somer.”

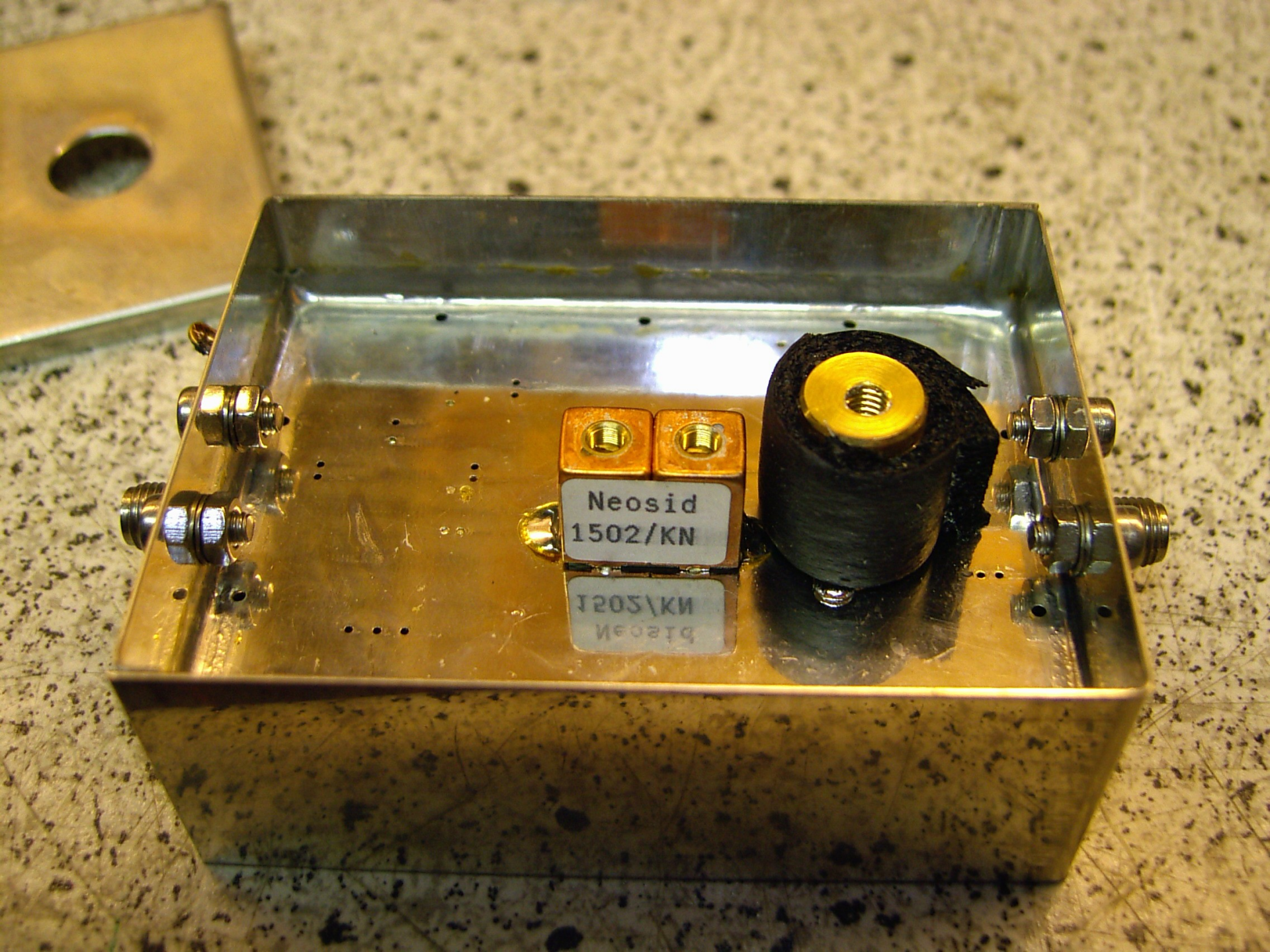

Neosid
1502/KN

1205/KN
NEOSID

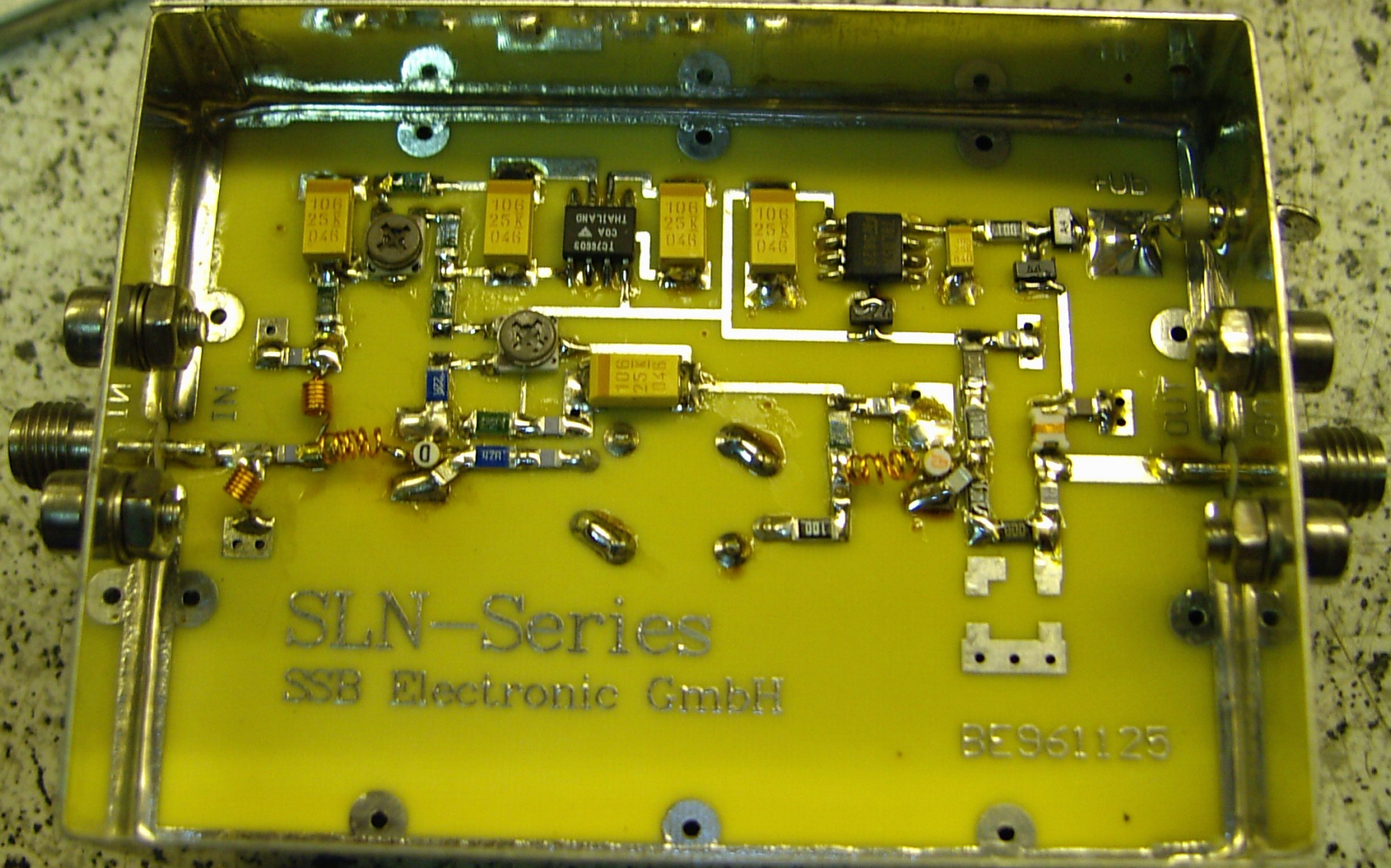

SLN-Series
SSB Electronic GmbH

BE961125

IN

IN

OUT

OUT

FUE

THAI LAND
COA
1G9809

100
25K
046

100
25K
046

100
25K
046

100
25K
046

100
25K
046

100

100

100

0

477

477

477

477

477

477

477

477

477

477

477

477

477

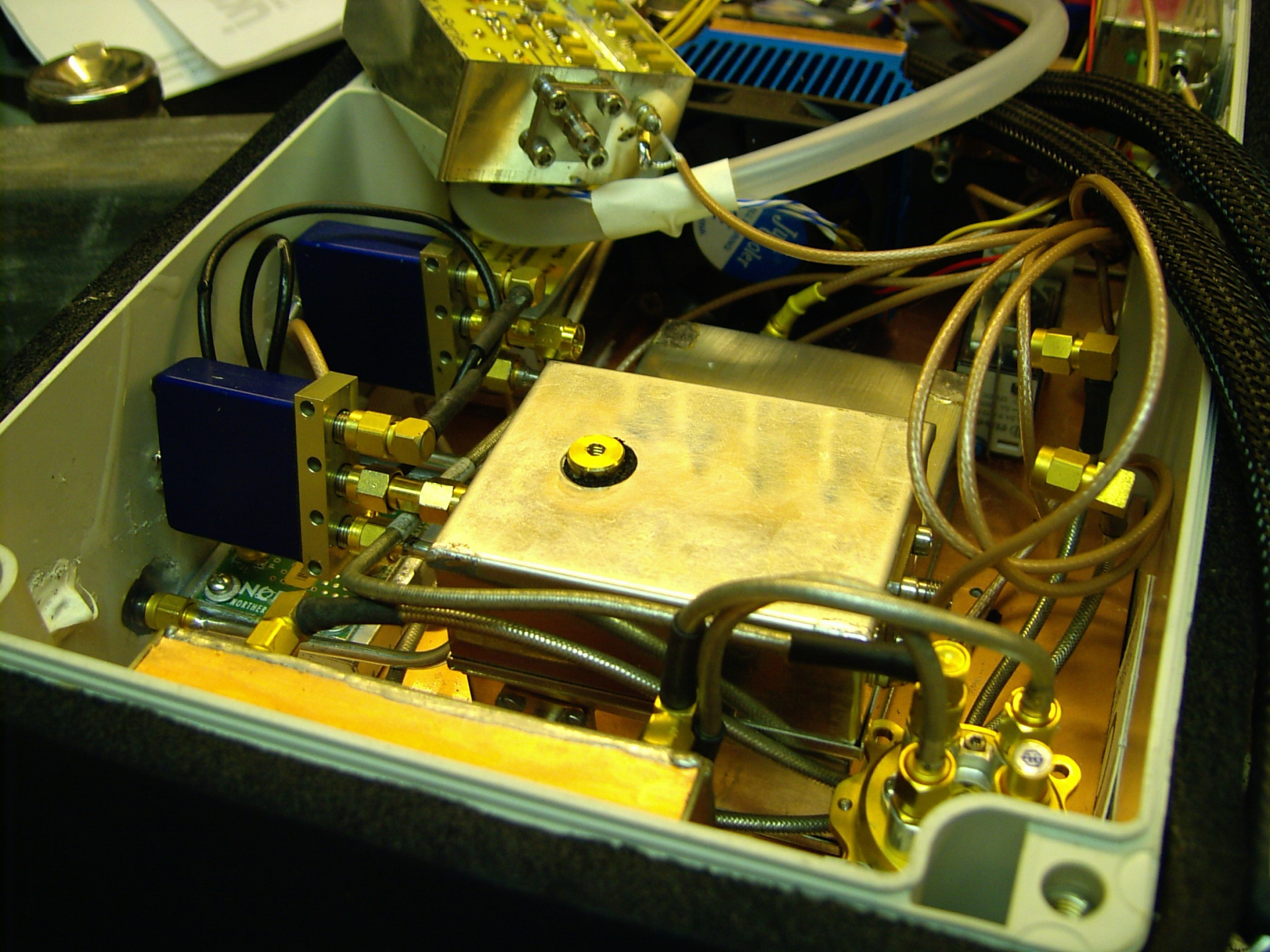

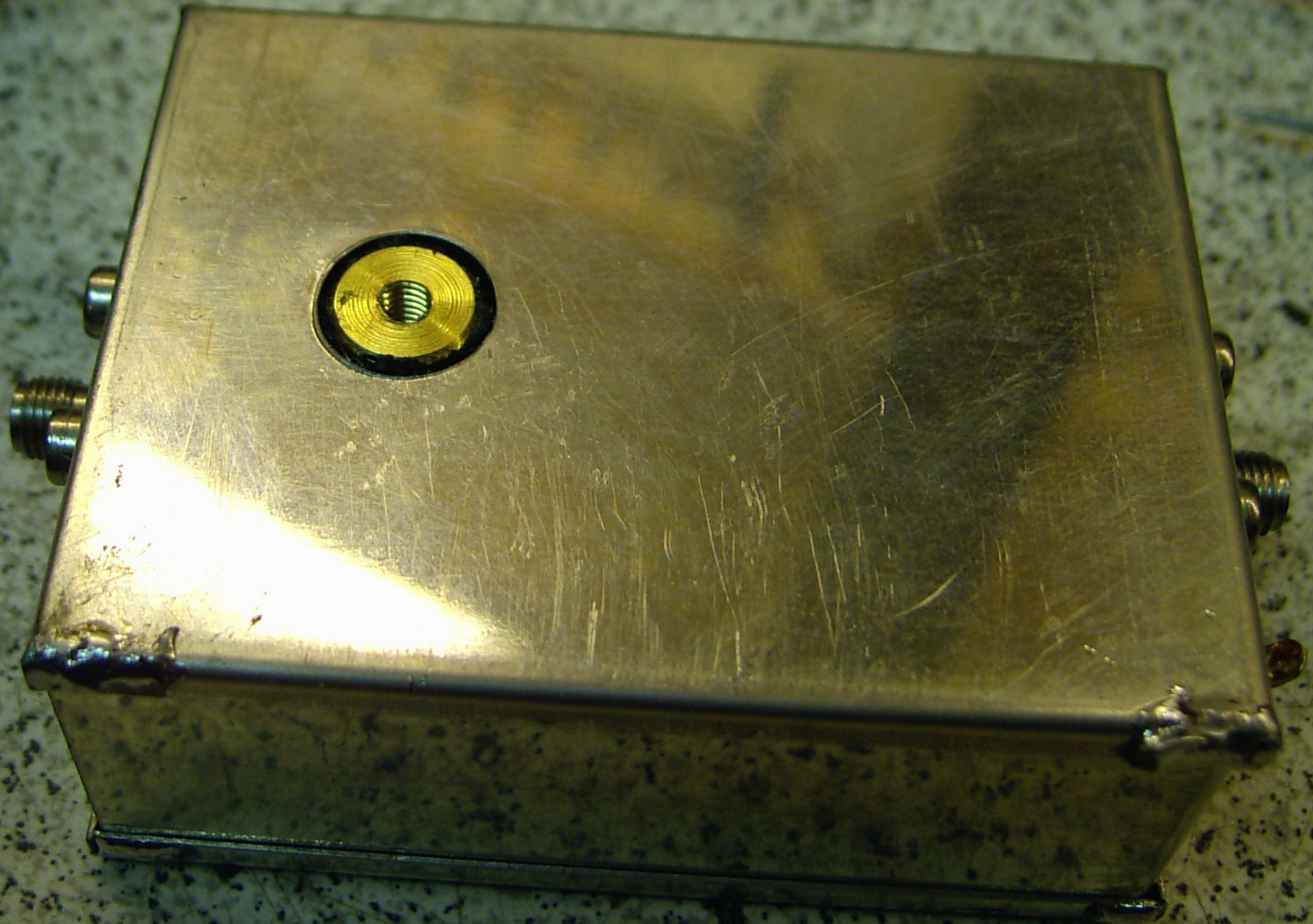

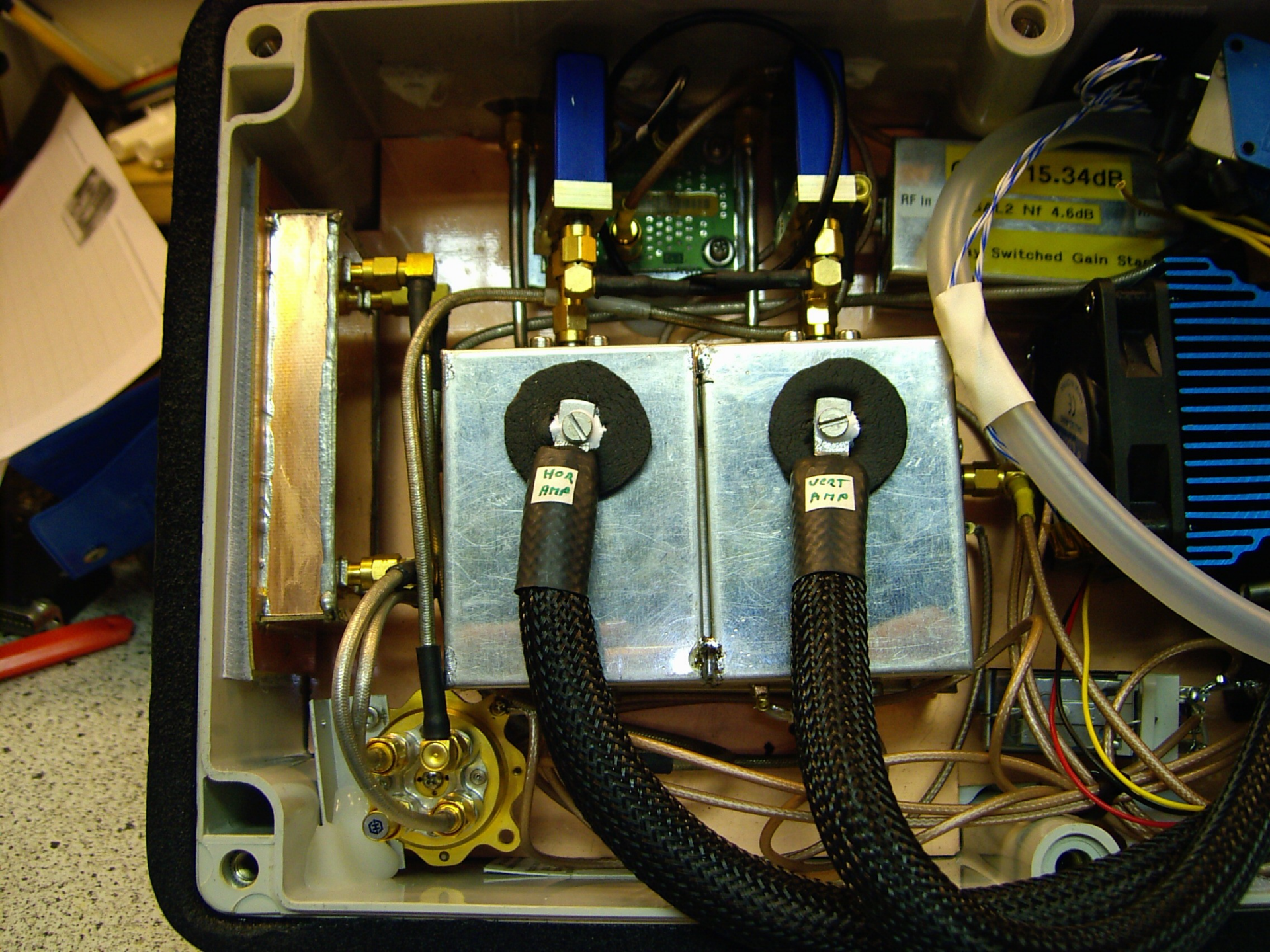

HOR
AMP

VERT
AMP

15.34dB
RF In
NF 4.6dB
Switched Gain Stage

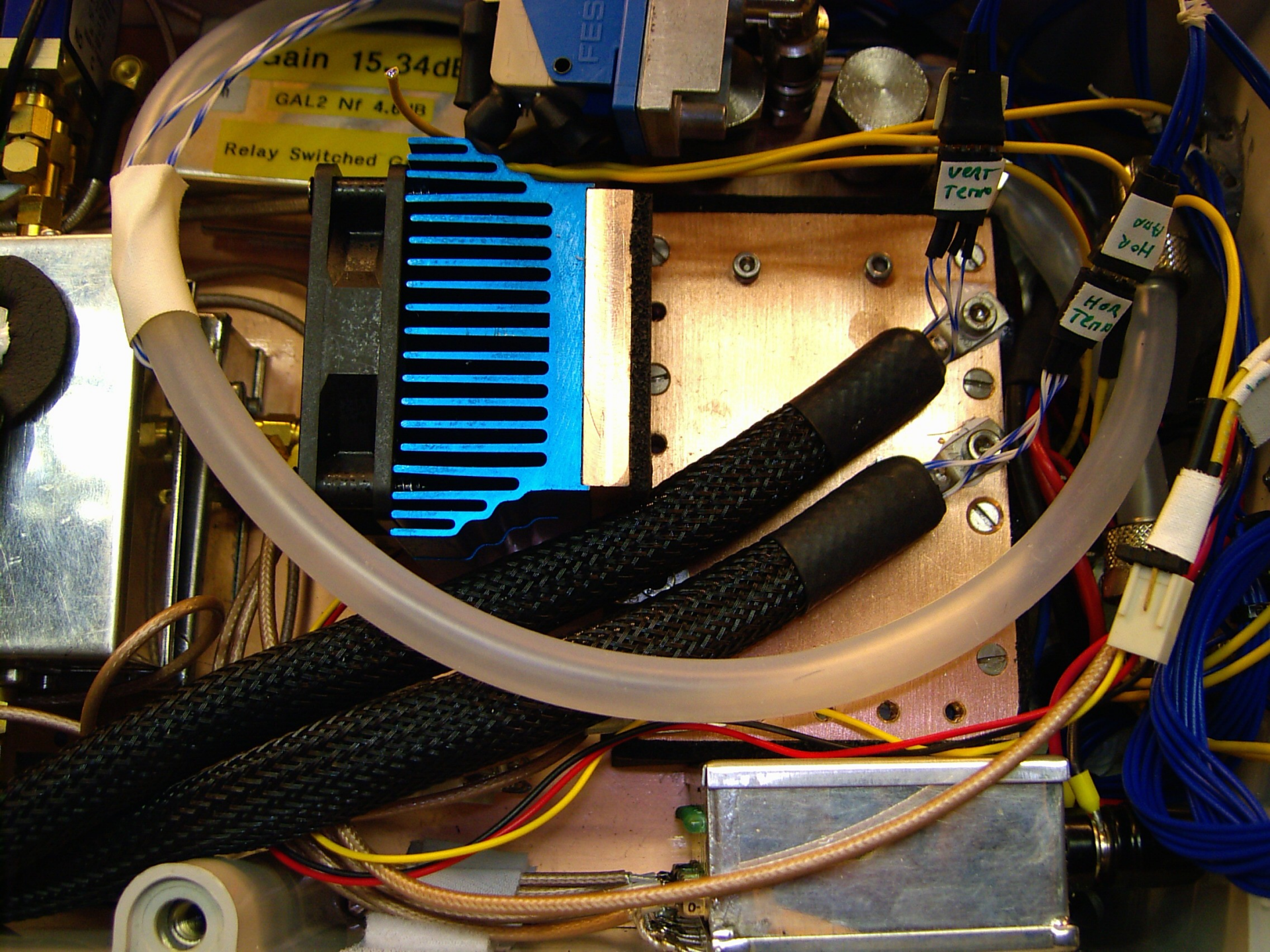

Gain 15.34dB

GAL2 NF 4.0dB

Relay Switched

PES

VOLT
Tenna

HOR
Tenna

0-

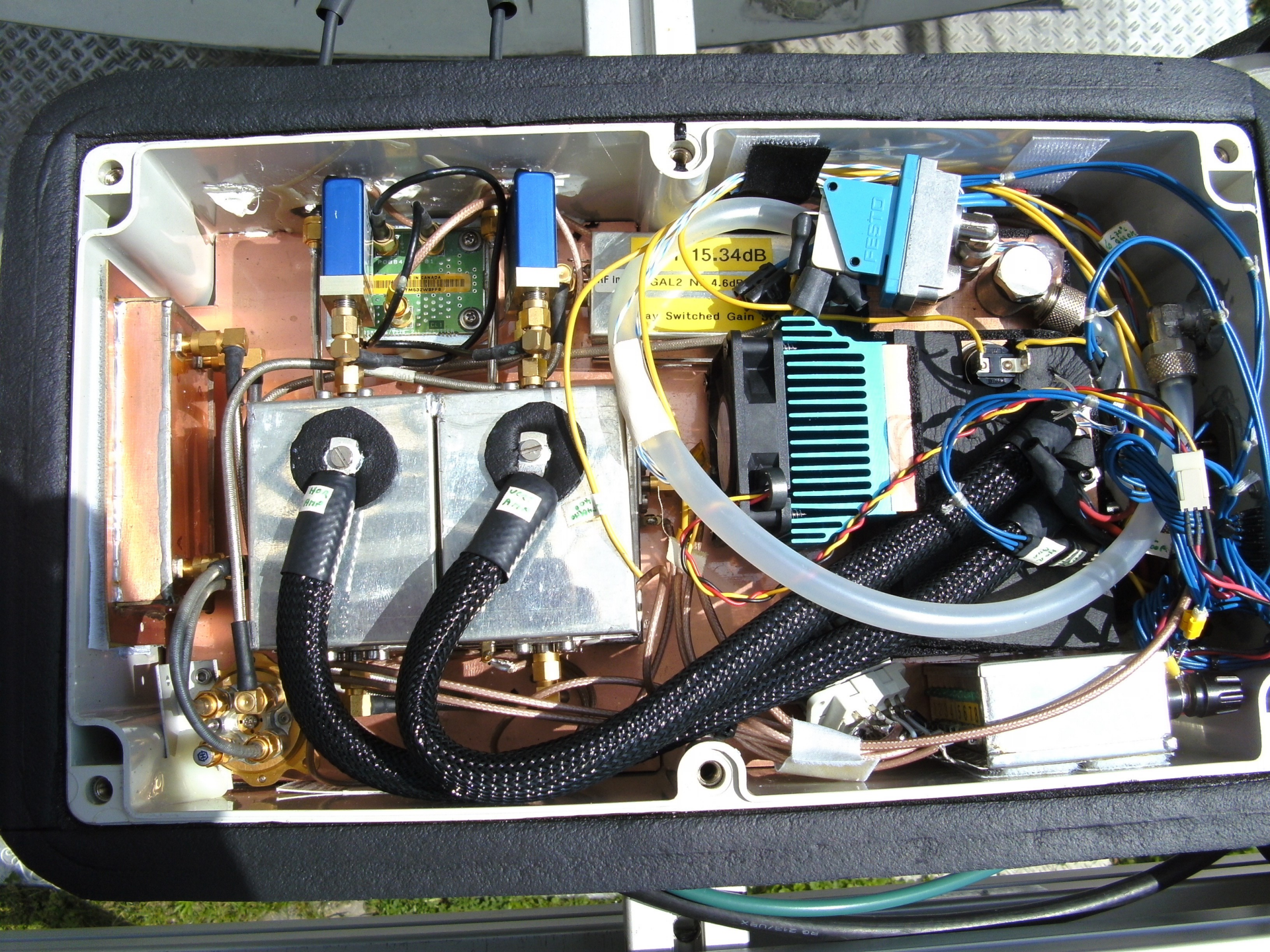

15.34dB

SAL2 N 4.6dB

ay Switched Gain

The Trick

- By Initial cooling the front end is cooled by the first stage Silicon oil First Slowly reducing the Temperature.
- Next both second stage Peltier are turned on till they settle down.
- Then the third stage is turned on, when the maximum temperature is reached one of the Second stage Peltier are turned off meaning that the Temperature and the volume flow of coolant keep the whole system stable.

The weak link

- Is the capacity of the Cryostat and the Ambient Temperature .
- Air is the intake cooling Medium, at a much later date I will be upgrading with a cold water Heat Exchanger and large underground tanks of cold water.

Condensed Water

- This problem is Easy using a Silicon GEL Bag and an air drying unit with a pipe connection to the LNA Box.
- You have not got to forget that the box Breaths with ambient temperature change and this dry air needs to expand with heat , without sucking in moist air to condense

Air Drying unit



The End

Any Questions

Peter Wright 2009